

PORTABURR 110 SERIES



By UltraMatic Equipment Co.

The leader in Vibratory Finishing since 1959



PORTABURR 5

PORTABURR 3

Today every nickle has to work like a dollar and for this reason your factory requires a Ultramatic PORTABURR SERIES Vibratory Finishing Machine. Two sizes are available: 3 and 5 cubic feet and are backed by a one year warranty. The PORTABURR is a heavy duty machine designed for full time industrial use. Introduced in 1980 and featuring our patented OVERHEAD DRIVE, (patent# 3991524), the PORTABURR is a proven design with thousands in the field today. Ask for literature on our complete line of round bowl, rectangular tub, multi-tub and flo-thru machines.

PORTABURR APPLICATIONS:

- ◆ Deburring fabricated aluminum or steel parts
- ◆ Polishing boat propellers
- ◆ Deburring aluminum die cast heat sinks
- ◆ Degreasing automotive starter/alternator housings
- ◆ Improve r.m.s surface finish on titanium ball valves
- ◆ Deburring machined pinion gears and spline shafts
- ◆ Pre-anodize finish on long extruded aluminum parts
- ◆ Deburring of bronze water meter housings

STANDARD FEATURES

PATENTED OVERHEAD DRIVE (OHD) an Ultramatic exclusive (patent # 3991524) produces a high energy vibratory action for faster cycle times and uniform mass roll throughout the tub length. The (OHD) design reduces the horsepower for energy efficient operation while extending the bearing & lining life making it far superior than competitor models with side or under the tub driveshaft locations.

SOUND REDUCTION PACKAGE features a hinged, base mounted sound cover which stays on the unit and foam lined metal cabinet which keeps noise levels as low as 80 dba.

HEAVY DUTY TUB is of all welded steel construction reinforced by gusset plates. The tub is stress relieved then shot-peened for maximum durability insuring years of trouble free use.

ADJUSTABLE AMPLITUDE the factory setting rarely needs adjustment however vibrating action can be changed by adding or subtracting counterweight on the drive shaft.

RUGGED POLYURETHANE TUB LINING is cast up to 5/8 " thick in the high wear area. The 85 durometer lining is abrasion resistant to withstand heavy loads providing many years of use. A removable urethane drain plug is included and is easily cleaned out periodically. The PORTABURR Model 3 has ribbed sidewalls to reduce flat parts sticking to sidewalls.

SINGLE PHASE OPERATION On-off switch with 6 ft. long cord and plug is provided for 110 volt operation. Switch includes outlet for compound pump to auto start/stop compound flow with machine.

SETTLING TANK with pump and hose for self contained recirculation of solution. Also converts to "flo-thru" setup for optimum part cleanliness.

CASTERS FOR PORTABILITY On Model 3

MEDIA DISCHARGE DOOR for change out of media.

WE MANUFACTURE PREFORMED MEDIA & LIQUID COMPOUNDS

We manufacture *HON-AN-CUT* ceramic and plastic media in a variety of compositions for deburring, finishing, polishing and radiusing any metal. Also try our line of *ULTRAFINISH* biodegradable liquid chemicals for burnishing, emulsifying light oils, descaling and rust inhibiting parts. Our no charge laboratory service can help you determine the best combination of media and compound for your application.

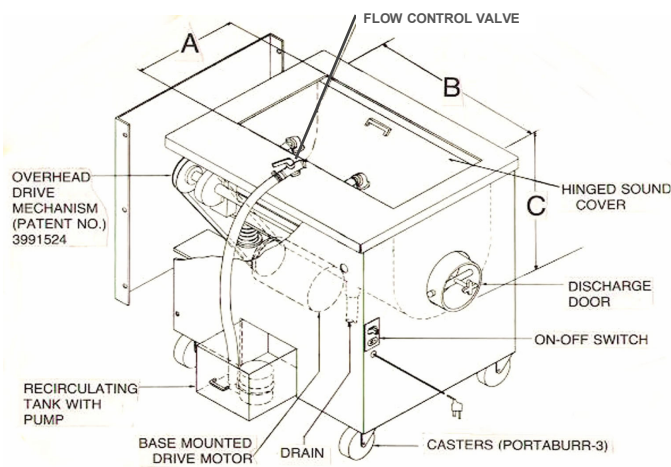
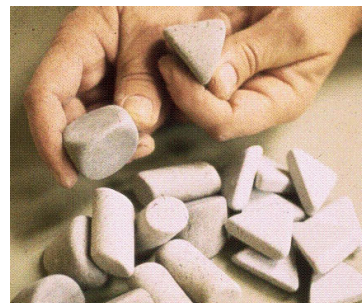

SIZE AND EXPERIENCE

In 1980 UltraMatic was one of the first companies to introduce a tub that would provide customers with a economical way to mass finish their parts. In addition to our patented overhead drive advantage check out the dimensions of the tub and compare with our nearest competitor. Ask for literature # 110 Tech for complete details and recommendation for part size capacity of our PORTABURR !!

PORTABURR MODEL	CU FT.	" A " TUB WIDTH	" B " TUB LENGTH	" C " TUB DEPTH	URETHANE LINING	MOTOR HP	SHIP WEIGHT	OVERALL FLOOR SPACE
3	3	15 "	28.5 "	15 "	1/2 "	3/4	650 lbs.	3 ' x 2.5 '
5	5	18 "	34.5 "	20 "	5/8 "	2	750 lbs.	3.5 ' x 3 '

UltraMATIC EQUIPMENT CO.
848 S. Westgate Drive
Addison, IL. 60101

PHONE: (630) 543-4565
FAX: (630) 543-4569
www.ultramatic-equipment.com