

UM Abrasives Preformed Plastic Media

UM Abrasives manufactures resin bond media in a variety of compositions using the highest quality raw materials. We have over 40 years experience to help you choose the media that is best suited for your parts. Our no charge laboratory facility is ready to process your sample parts.

COMPOSITIONS		Lbs / Cu. Ft.
XFF 3	FINEST FINISH LIGHT CUTTING MEDIA COMPOSED OF ULTRA FINE BUFFING ABRASIVES. USE IT FOR A SUPER PRE-PLATE FINISH AND LOW R.M.S. RESULTS. COLOR: BLUE	60
FF 1	FINEST FINISH GOOD CUTTING GENERAL PURPOSE MEDIA AND FOR PRE-PLATE FINISHING. COLOR: GREEN	60
FC 1	SUPER FAST CUTTING, GOOD FINISHING MEDIA. THIS IS OUR ALUMINUM OXIDE BASED COMPOSITION FOR HEAVY CUTDOWN ON ANY METAL , EVEN FOR SURFACE BLENDING STAINLESS STEEL. COLOR: DARK GREY	70
PSC	SUPER FAST CUTTING MEDIA WITH SILICON CARBIDE ABRASIVES FOR THE MOST AGGRESSIVE CUTDOWN AND SURFACE BLENDING. GOOD CHOICE WHEN PARTS ARE TO BE WELDED OR BRAZED AFTER THE VIBRATORY PROCESS. COLOR: GREY	65
CD 1	HIGH DENSITY PRE PLATE FINISH MEDIA FORMULATED WITH ZIRCON FLOUR ABRASIVES. PROVIDES A SMOOTH BRIGHT MATTE FINISH THAT CAN READILY BE BUFFED OR PLATED. RUNS EXTREMELY CLEAN. COLOR: WHITE	70
HLF	PRE PLATE FINISH GOOD CUTTING MEDIA THAT IS LOW FOAMING, LONG LASTING AND RUNS EXTREMELY CLEAN.	60
HLF 2	SPECIFICALLY FORMULATED PLASTIC MEDIA DEVELOPED FOR USE WITH ACCELERATED CHEMICALS. PROVIDES A GREAT PRE PLATE FINISH ON PARTS RANGING FROM FERROUS METALS TO BRASS. COLOR: AMBER	63



UM Abrasives Inc.
 Phone: (817) 572-1344
 Fax: (817) 483-9634
 Email: sales@umabrasives.com



STANDARD PLASTIC MEDIA SIZES



Cones

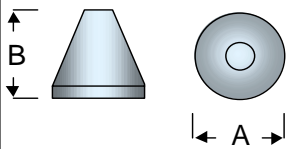

A	B
2	2
1 1/2	1 1/2
1 1/4	1 1/4
1	1 1/4
3/4	3/4
9/16	9/16
3/8	3/8

Isosceles Triangles



A	B
1 1/4	5/8
7/8	1/2
3/8	3/8
1/4	1/4

V Cut Cylinders

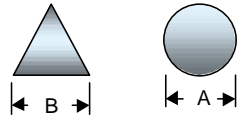

A	B
2	2
1 1/2	1 1/2
1	1
7/8	7/8
5/8	5/8
1/2	1/2

Four Sided Triangle



A	B
1 1/2	1
1	5/8

Tristars



A	B
1 3/8	1/2

Angle Cut Prisms



A	B
7/8	1

Trimids



A	B
1 1/2	1 1/2
1 1/4	1 1/4

Pyramids



A	B
2	2
1 5/8	1

Tapered Arrowhead



A	B	C
1 3/4	1	1/2

For price and delivery or technical assistance our team will respond to your email within hours. Please provide as much detail as possible.
 Email: sales@umabrasives.com

U.M. Abrasives
 831 Trent St
 Kennedale, TX. 76060
 (817)572-1344 (817) 483-9634 Fax
 Website: umabrasives.com